

# VU-26 Flat Panel LCD Monitor

The VU-26 offers an eye-popping picture at 1920 x 1080 resolution. This LCD flat panel monitor works well for any number of applications, where a large viewing area is critical. This stunning addition to the Dage-MTI line of high performance monitors uses advanced video technology for an extremely high quality picture.



## FEATURES

- 26" 16:9 LCD Monitor
- Brightness 500cd/m<sup>2</sup>
- Contrast 1000:1
- Inputs Composite, S-Video, YPbPr , VGA, DVI
- 3D Comb Filter
- Dynamic Noise Reduction

## SPECIFICATIONS

System	PAL, NTSC	
VGA	Display Panel	LCD
	Resolution	1920 X 1080
	Brightness	500cd/m <sup>2</sup>
	Contrast	1000:1
	Response Time	8ms
	Viewing Angle	176°/176°
Video Input/Output	Composite Video Input	2 channel BNC input 1.0v p-p, 75Ω
	S-Video	2 channel input
	YPbPr	2 channel input
	DVI	2 channel input
	VGA	2 channel input
Audio	3 channel input, 2W	
Menu	OSD	
Dimension	673 X 421 X 125 (mm)	
Weight	12kg	
Power Source	Voltage	AC 100~230V 50~60Hz
	Power	Max 110W
Operating Environment	Operating Temperature: 0° C~40° C; Operating Humidity: 10% ~ 85%	

## VU-26 FLAT PANEL LCD MONITOR

### FRONT PANEL CONTROLS

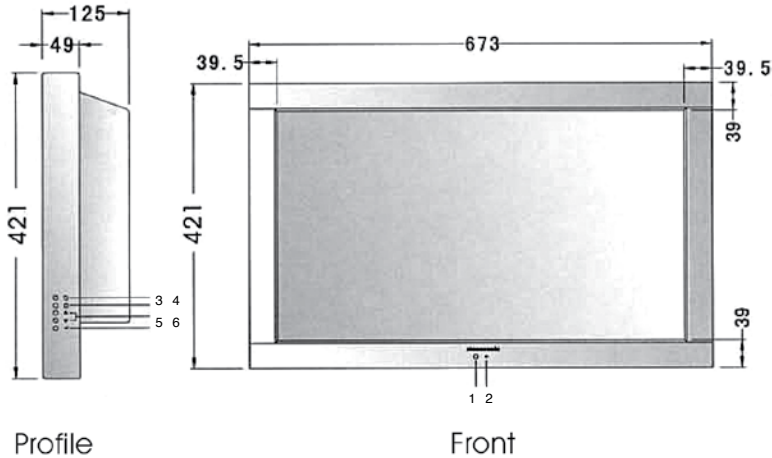

1. Remote IR
2. Blue: on; Red: standby
3. Input select: AV1, AV2, S-Video, YPbPr, VGA and DVI
4. OSD On/Off
4. Power
5. a. OSD off: adjust volume (range 1-100)  
b. OSD on: select forward/backwards  
c. Change current value or function of item selected
6. Select current item

### REAR PANEL CONTROLS

7. RGB/YUV: YPbPr In  
(RGB function not available)
8. Video 1: VIDEO 1 IN/OUT
9. Video 2: VIDEO 2 IN/OUT
10. SVHS: S-Video IN/OUT
11. AUDIO1: VIDEO 1, S-VIDEO AUDIO IN/OUT
12. AUDIO2: VIDEO2, YPbPr AUDIO IN/OUT
13. AUDIO3: VGA, DVI AUDIO IN/OUT
14. VGA: VGA IN
15. Central Keyboard Control (optional)
16. DVI: DVI IN
17. Power Switch

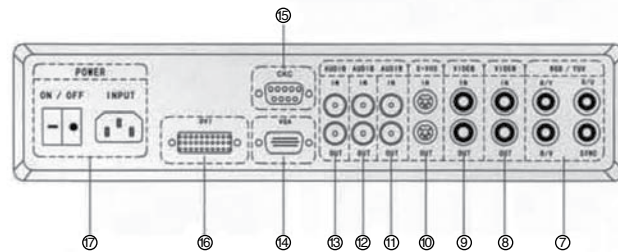
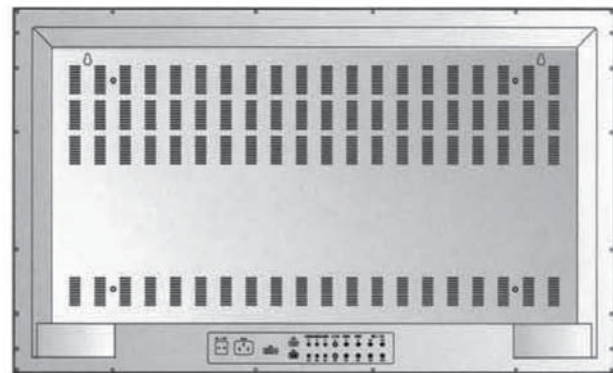

Back



**Dage-MTI (219) 872-5514**

Call for additional product information or free product demos.

Visit online at [www.dagemti.com](http://www.dagemti.com).